

3 Wire cable trays

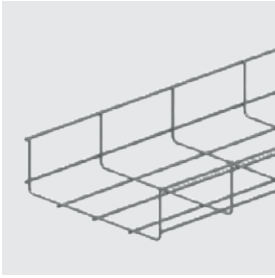

VFUL

VFUL35	Wire cable tray	77
VFUL60	Wire cable tray	78

VFU

VFU35	Wire cable tray for heavy duty	79
VFU60	Wire cable tray for heavy duty	80
VFU85	Wire cable tray for heavy duty	81
VFU110	Wire cable tray for heavy duty	82

GVFUL

GVFUL	G-shaped wire cable tray	82
-------	--------------------------	----

COVER

D	Universal cover	83
---	-----------------	----

COVER CLAMPS

DCLVF	Cover clamp clips	83
DCLVF35	Cover clamp clips	84

ACCESSORIES

VFO	Suspension piece for VFU(L)	84
VFOCL	Snap-in suspension for VFU(L)	84
VFM	Wall bracket for VFU(L)	85
VFMM	Wall and mounting bracket for VFU(L)	85
VFMM35	Wall and mounting bracket for VFU(L)	85
VFCL	Fixing clips for VFU(L)	86
VFCB	Central suspension bracket	86
OBG	Upper bracket	87
OBGVF	Open C-suspension bracket for VFU(L)	87
BGVF	External suspension bracket for VFU(L)	88
VFVLB	Floor bracket for VFU(L)	88
ZCL	Z-support clippable	89
MPVFCL	Profile for VFU(L)	89
COMEGACLU170	Open suspension bracket universal	90
COMEGACLU290	Open suspension bracket universal	91
LOMEGACLU150	Wall bracket universal	92
VMB	Floor and wall bracket	93
SLOS	Bolt-in partition	93
VFSLOSCL	Clips for fixing SLOS to VFU(L)	94

Joiner

VFK	Joining clamp	94
VFKG30	Joining clamp for VFU(L)	94
VFKK25	Joining clamp for VFU(L)	95
VFKS	Support joiner for VFU(L)	95
KPVF	Snap-on joiner for VFU(L)	96
KPVFL35	Snap quick-joiner for VFU(L)35	96
V35.200	Joiner	96

ROOF SUPPORT

RSM	Universal Roof Support	97
RSL	Universal Roof Support Large	97

TOOLS

VFKNIP	Bolt cutter	97
--------	-------------	----

	TECHNICAL INFORMATION	99
--	-----------------------	----

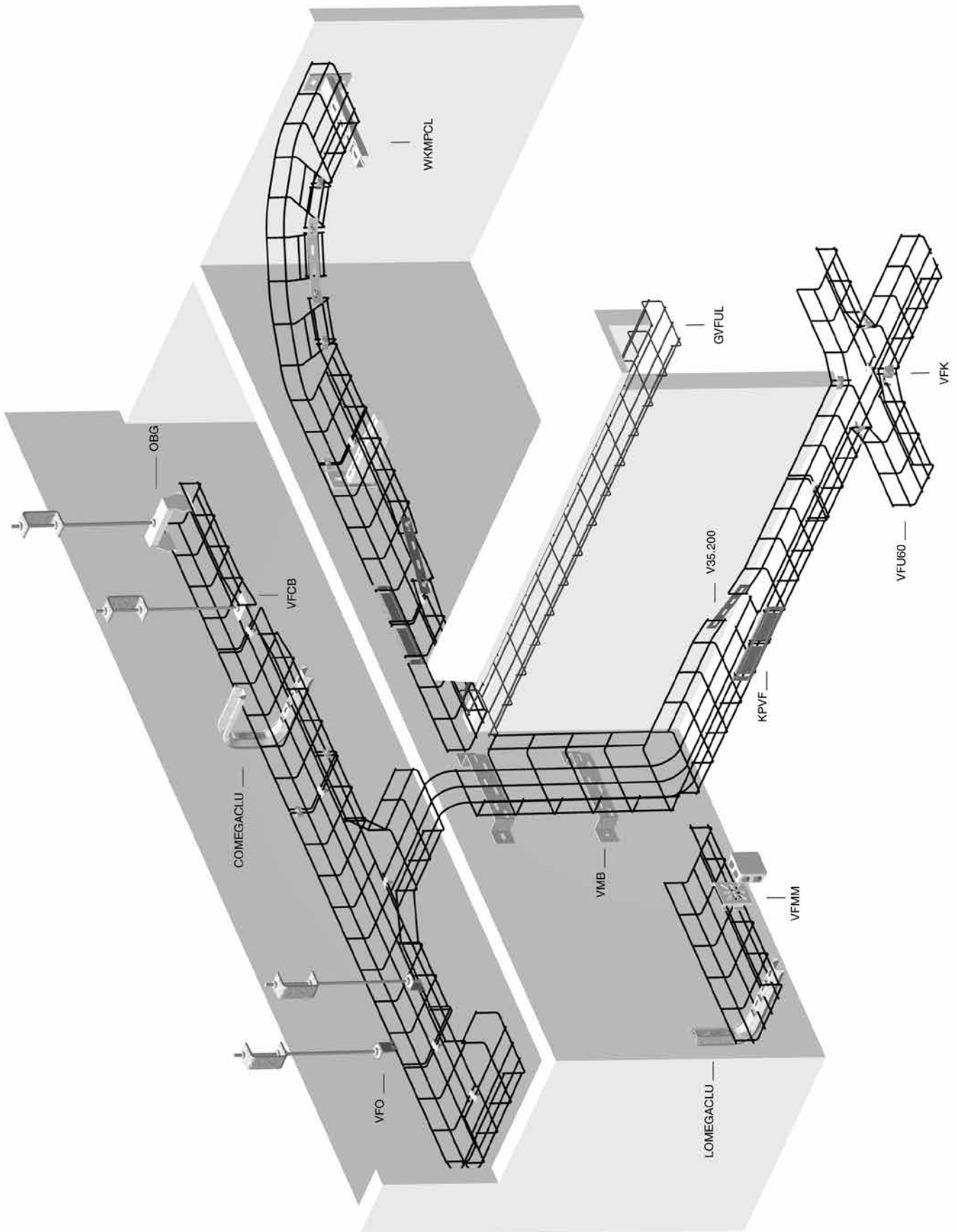

VFUL35

Wire cable tray

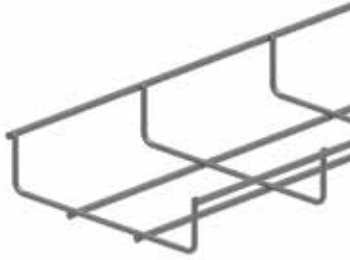

Screen: 50 x 100 mm
Cross-wire: Ø 3.50 mm
Lengthwise wire: Ø 4.50 mm

Standard finish	Pre-galvanised
Optional finish	zinc aluminium
Optional finish PE	Coating

HD	Reference	↓ mm	↔ mm	↔ mm	↔ mm	kg/m	📦	Stock	Unit
-	VFUL30.065	30	65		3000	0.530	15	X	m
-	VFUL35.100	35	95		3000	0.570	30	X	m
-	VFUL35.150	35	146		3000	0.830	30	X	m
HD	VFUL35.200	35	196		3000	0.870	30	X	m
HD	VFUL35.250	35	245		3000	1.030	30	X	m
HD	VFUL35.350	35	345		3000	1.330	30	X	m
-	ZAVFUL30.065	30	65		3000	0.530	15		m
-	ZAVFUL35.100	35	95		3000	0.570	30		m
-	ZAVFUL35.150	35	146		3000	0.830	30		m

Fix with:

ZM	KPVFL35	45	248	-	-	0.100	30	X	piece
HD	VFK	-	-	-	-	0.020	100	X	piece

LOAD DIAGRAM

This diagram illustrates the permissible uniformly distributed loads applied to multiple supports. They comply with IEC 61537 with connection to 1/5 of the span and the end span = 0,8x the span. When the joint is situated in the centre of the span, a reduction of 0,7x the admissible load is to be taken into account.

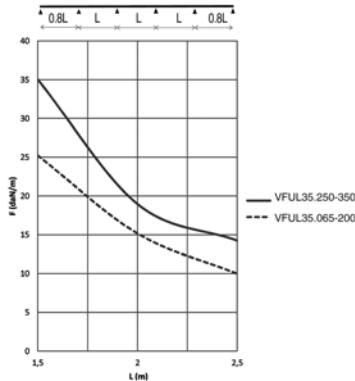

F = max. admissible load (daN/m)

L = support distance (m)

Max. deflection (m) = L/100

VFUL30.065 coupling only with VFK.

Our VFUL35 wire cable tray is now available in zinc aluminum (ZA). This coating offers at least as much corrosion resistance as the standard hot-dip galvanizing process.

Zinc aluminum (ZA) is identified with a small plate.

Usable inside height: outside height - 7mm

Usable inside width: outside width - 15mm

VFUL60

Wire cable tray

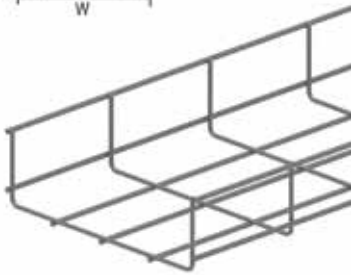

Screen: 50 x 100 mm
 Cross-wire: Ø 3.50 mm
 Lengthwise wire: Ø 4.50 mm

Standard finish	Pre-galvanised
Optional finish	zinc aluminium
Optional finish PE	Coating

HD	Reference	↑ mm	↔ mm	→ ← mm	↔ mm	kg/m	📦	Stock	Unit
-	VFUL60.050	60	50		3000	0.570	30	X	m
-	VFUL60.100	60	96		3000	0.830	30	X	m
-	VFUL60.150	60	146		3000	0.870	30	X	m
-	VFUL60.200	60	197		3000	1.030	30	X	m
-	VFUL60.300	60	297		3000	1.330	30	X	m
-	ZAVFUL60.050	60	50		3000	0.570	30		m
-	ZAVFUL60.100	60	96		3000	0.830	30		m
-	ZAVFUL60.150	60	146		3000	0.870	30		m
-	ZAVFUL60.200	60	197		3000	1.030	30		m
-	ZAVFUL60.300	60	297		3000	1.330	30		m

Fix with:									
HD	VFKS	55	250	-	-	0.270	20	X	piece
ZM	KPVF	51	248	-	-	0.100	30	X	piece
HD	VFK	-	-	-	-	0.020	100	X	piece

LOAD DIAGRAM

This diagram illustrates the permissible uniformly distributed loads applied to multiple supports. They comply with IEC 61537 with connection to 1/5 of the span and the end span = 0,8x the span. When the joint is situated in the centre of the span, a reduction of 0,7x the admissible load is to be taken into account.

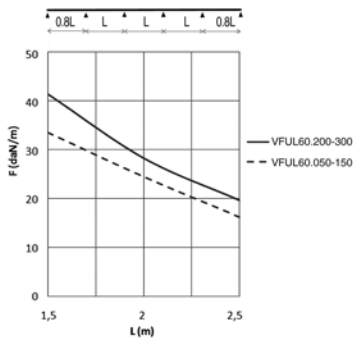

F = max. admissible load (daN/m)
 L = support distance (m)
 Max. deflection (m) = L/100

NEW

Our VFUL60 wire cable tray is now available in zinc aluminium (ZA). This coating offers a corrosion protection at least as long as the standard hot dip galvanizing process.

Zinc aluminium (ZA) is identified with a small plate.

Usable inside height: outside height - 7mm

Usable inside width: outside width - 15mm

VFU35

Wire cable tray for heavy duty

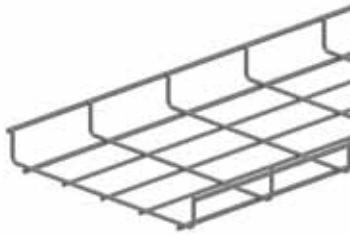

Screen: 50 x 100 mm
Wire: Ø 4.50 mm and 5.50 mm

Standard finish	Pre-galvanised
Optional finish	Hot-dip galvanised
Optional finish PE	Coating

HD	Reference	↓ mm	↔ mm	↔ mm	↔ mm	kg/m	⊠	Stock	Unit
HD	VFU35.150	35	148		3000	1.200	30		m
HD	VFU35.250	35	248		3000	1.430	30		m
HD	VFU35.350	35	348		3000	1.780	30		m
HD	VFU35.450	35	448		3000	2.120	30		m
HD	VFU35.550	35	548		3000	2.470	30		m

Fix with:

ZM	KPVFL35	45	248	-	-	0.100	30	X	piece
HD	VFK	-	-	-	-	0.020	100	X	piece

LOAD DIAGRAM

This diagram illustrates the permissible uniformly distributed loads applied to multiple supports. They comply with IEC 61537 with connection to 1/5 of the span and the end span = 0,8x the span. When the joint is situated in the centre of the span, a reduction of 0,7x the admissible load is to be taken into account.

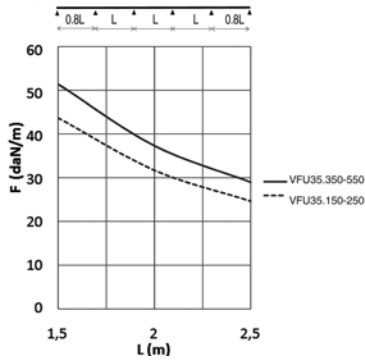

F = max. admissible load (daN/m)

L = support distance (m)

Max. deflection (m) = L/100

Usable inside height: outside height - 9mm

Usable inside width: outside width - 17mm

VFU60

Wire cable tray for heavy duty

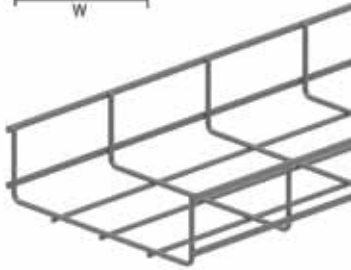

Screen: 50 x 100 mm
Wire: Ø 4.50 mm and 5.50 mm

Standard finish	Pre-galvanised
Optional finish	Hot-dip galvanised
Optional finish PE	Coating

HD	Reference	↑ mm	↔ mm	↔ mm	↔ mm	kg/m	📦	Stock	Unit
HD	VFU60.100	60	99		3000	1.200	30	X	m
HD	VFU60.200	60	199		3000	1.430	30	X	m
HD	VFU60.300	60	299		3000	1.780	30	X	m
HD	VFU60.400	60	399		3000	2.120	30	X	m
HD	VFU60.500	60	499		3000	2.470	30	X	m
HD	VFU60.600	60	599		3000	2.810	30	X	m

Fix with:									
HD	VFKS	55	250	-	-	0.270	20	X	piece
ZM	KPVF	51	248	-	-	0.100	30	X	piece
HD	VFK	-	-	-	-	0.020	100	X	piece

LOAD DIAGRAM

This diagram illustrates the permissible uniformly distributed loads applied to multiple supports. They comply with IEC 61537 with connection to 1/5 of the span and the end span = 0,8x the span. When the joint is situated in the centre of the span, a reduction of 0,7x the admissible load is to be taken into account.

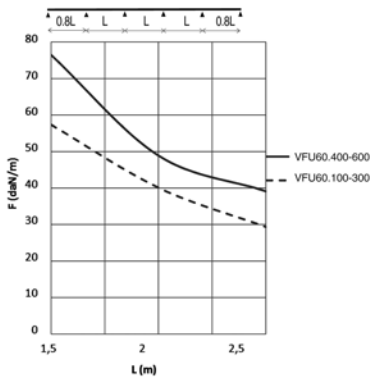

F = max. admissible load (daN/m)
L = support distance (m)
Max. deflection (m) = L/100

Usable inside height: outside height - 9mm
Usable inside width: outside width - 17mm

VFU85

Wire cable tray for heavy duty

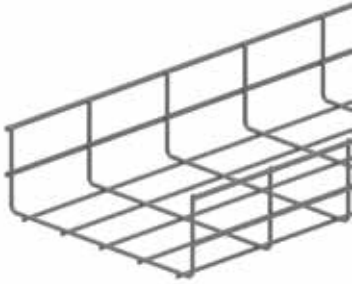

Screen: 50 x 100 mm
Wire: Ø 4.50 mm and 5.50 mm

Standard finish	Pre-galvanised
Optional finish	Hot-dip galvanised
Optional finish PE	Coating

HD	Reference	↓ mm	↔ mm	↔ mm	↔ mm	kg/m	📦	Stock	Unit
HD	VFU85.150	85	148		3000	1.430	30		m
HD	VFU85.250	85	248		3000	1.780	30		m
HD	VFU85.350	85	348		3000	2.120	30		m
HD	VFU85.450	85	448		3000	2.470	30		m

Fix with:									
ZM	KPVF	51	248	-	-	0.100	30	X	piece
HD	VFK	-	-	-	-	0.020	100	X	piece

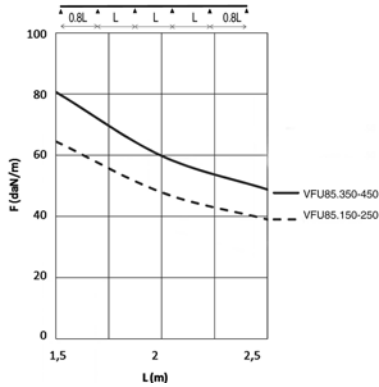

LOAD DIAGRAM

This diagram illustrates the permissible uniformly distributed loads applied to multiple supports. They comply with IEC 61537 with connection to 1/5 of the span and the end span = 0,8x the span. When the joint is situated in the centre of the span, a reduction of 0,7x the admissible load is to be taken into account.

F = max. admissible load (daN/m)
L = support distance (m)
Max. deflection (m) = L/100

Usable inside height: outside height - 9mm
Usable inside width: outside width - 17mm

VFU110

Wire cable tray for heavy duty

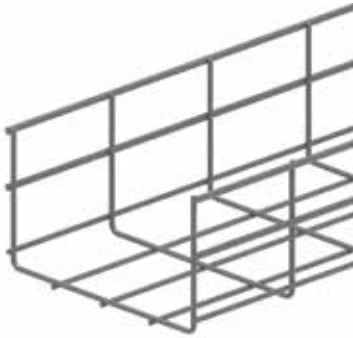

Screen: 50 x 100 mm
 Wire: Ø 4.50 mm and 5.50 mm

Standard finish	Pre-galvanised
Optional finish	Hot-dip galvanised
Optional finish PE	Coating

HD	Reference	↑ mm	↔ mm	→ ← mm	↔ mm	kg/m	📦	Stock	Unit
HD	VFU110.200	110	199		3000	1.780	30		m
HD	VFU110.300	110	299		3000	2.120	30		m
HD	VFU110.400	110	399		3000	2.470	30		m

Fix with:

ZM	KPVF	51	248	-	-	0.100	30	X	piece
HD	VFK	-	-	-	-	0.020	100	X	piece

LOAD DIAGRAM

This diagram illustrates the permissible uniformly distributed loads applied to multiple supports. They comply with IEC 61537 with connection to 1/5 of the span and the end span = 0,8x the span. When the joint is situated in the centre of the span, a reduction of 0,7x the admissible load is to be taken into account.

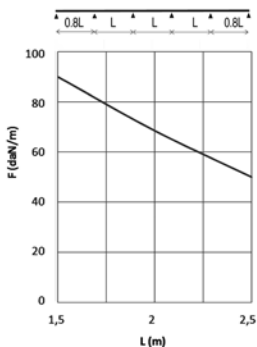

F = max. admissible load (daN/m)

L = support distance (m)

Max. deflection (m) = L/100

Usable inside height: outside height - 9mm

Usable inside width: outside width - 17mm

GVFUL

G-shaped wire cable tray



For fixing directly to the ceiling with VFCB.

Standard finish	Pre-galvanised
Optional finish	Hot-dip galvanised
Optional finish PE	Coating

HD	Reference	↑ mm	↔ mm	→ ← mm	↔ mm	kg/m	📦	Stock	Unit
HD	GVFUL55.100	55	91		3000	0.830	30	X	m
HD	GVFUL60.150	64	154		3000	1.030	30	X	m
HD	GVFUL100.100	102	109		3000	1.030	30	X	m
HD	GVFUL100.150	105	160		3000	1.330	30	X	m

Fix with:

HD	VFK	-	-	-	-	0.020	100	X	piece
----	------------	---	---	---	---	-------	-----	---	-------

The technical information for this product can be found at the end of this chapter.

D Universal cover

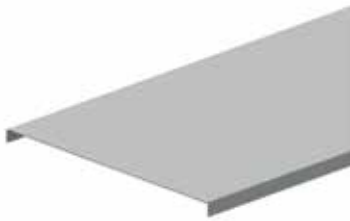

Especially used for horizontal and vertical sections.
Cover with board height of 10 mm.

Standard finish	Pre-galvanised
Optional finish	zinc magnesium
Optional finish PE	Coating

HD	Reference	↓ mm	↔ mm	↔ mm	↔ mm	kg/m	📦	Stock	Unit
-	D050	10	50		3000	0.350	30	X	m
-	D075	10	75		2000	0.500	20	X	m
-	D100	10	100		2000	0.703	20	X	m
-	D150	10	150		2000	1.170	20	X	m
-	D200	10	200		2000	1.420	20	X	m
-	D250	10	250		2000	1.850	20	X	m
-	D300	10	300		2000	2.100	20	X	m
-	D400	10	400		2000	4.150	20	X	m
-	D500	10	500		2000	5.000	2	X	m
-	D600	10	600		2000	5.650	2	X	m
-	ZMD050	10	50		3000	0.328	30	X	m
-	ZMD075	10	75		2000	0.445	20	X	m
-	ZMD100	10	100		2000	0.562	20	X	m
-	ZMD150	10	150		2000	0.796	20	X	m
-	ZMD200	10	200		2000	1.030	20	X	m
-	ZMD250	10	250		2000	1.580	20	X	m
-	ZMD300	10	300		2000	1.872	20	X	m
-	ZMD400	10	400		2000	2.948	20	X	m
-	ZMD500	10	500		2000	3.650	2	X	m
-	ZMD600	10	600		2000	4.352	2	X	m

Fix with:

-	DCLVF	-	-	-	-	0.005	100	X	piece
-	DCLVF35	-	-	-	-	0.005	100	X	piece

Covers with width > 400 mm are delivered with diagonal reinforcements.

DCLVF Cover clamp clips



For VFU(L)60, VFU85 and VFU110.
Number: 2 pieces per metre.

Standard finish	Stainless Steel
-----------------	-----------------

HD	Reference	↓ mm	↔ mm	↔ mm	↔ mm	kg/ piece	📦	Stock	Unit
-	DCLVF	-				0.005	100	X	piece

The technical information for this product can be found at the end of this chapter.

To order per full packaging.

DCLVF35

Cover clamp clips



For VFU(L)35.
Number: 2 pieces per metre.

Standard finish Stainless Steel

HD	Reference	↕ mm	↔ mm	↔ mm	↔ mm	kg/ piece	📦	Stock	Unit
-	DCLVF35	-			-	0.005	100	X	piece

The technical information for this product can be found at the end of this chapter.

To order per full packaging.
Do not use with: VFUL30.065.

VFO

Suspension piece for VFU(L)



Standard finish Pre-galvanised

Optional finish Hot-dip galvanised

Optional finish PE Coating

HD	Reference	↕ mm	↔ mm	↔ mm	↔ mm	kg/ piece	📦	Stock	Unit
HD	VFO	-			-	0.030	20	X	piece

To order per full packaging.
For threaded rod suspension M6/M8.
Threaded rod 'TIM6' or 'TIM8' should be ordered separately.

VFOCL

Snap-in suspension for VFU(L)



Standard finish Electro zinc-plated

HD	Reference	↕ mm	↔ mm	↔ mm	↔ mm	kg/ piece	📦	Stock	Unit
-	VFOCL	67	25		-	0.035	20	X	piece

To order per full packaging.
For threaded rod suspension TIM6 or TIM8.
Threaded rod should be ordered separately.

VFM

Wall bracket for VFU(L)



Up to width of 200 mm.

Standard finish	Pre-galvanised
Optional finish	Hot-dip galvanised
Optional finish PE	Coating

HD	Reference	↑ mm	↔ mm	→ ← mm	↔ mm	kg/ piece	📦	Stock	Unit
HD	VFM	-			-	0.030	20	X	piece

To order per full packaging.

VFMM

Wall and mounting bracket for VFU(L)



For VFU(L)60, VFU85, VFU110

Standard finish	Pre-galvanised
Optional finish	Hot-dip galvanised
Optional finish PE	Coating

HD	Reference	↑ mm	↔ mm	→ ← mm	↔ mm	kg/ piece	📦	Stock	Unit
HD	VFMM	75			-	0.090	12	X	piece

The technical information for this product can be found at the end of this chapter.

To order per full packaging.

VFMM35

Wall and mounting bracket for VFU(L)



For VFU(L)35

Standard finish	Pre-galvanised
Optional finish	Hot-dip galvanised
Optional finish PE	Coating

HD	Reference	↑ mm	↔ mm	→ ← mm	↔ mm	kg/ piece	📦	Stock	Unit
HD	VFMM35	57			-	0.120	12	X	piece

To order per full packaging.

VFCL

Fixing clips for VFU(L)



For fixing of wire cable tray on the bracket.

Standard finish

Electro zinc-plated

HD	Reference	↑ mm	↔ mm	→ ← mm	↔ mm	kg/ piece	📦	Stock	Unit
-	VFCL	-			-	0.010	100	X	piece

To order per full packaging.

VFCEB

Central suspension bracket

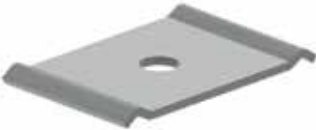

Standard finish

Pre-galvanised

Optional finish

Hot-dip galvanised

Optional finish PE

Coating

HD	Reference	↑ mm	↔ mm	→ ← mm	↔ mm	kg/ piece	📦	Stock	Unit
HD	VFCEB	-			-	0.035	60	X	piece

To order per full packaging.

2 pieces for threaded rod suspension M6/M8.

Can be used for wire cable trays: VFUL35.100, VFU(L)60.100, VFUL60.150

1 piece for direct mounting to the ceiling

Can be used for wire cable trays: GVFUL55.100, GVFUL60.150, GVFUL100.100 and GVFUL100.150.

OBG

Upper bracket

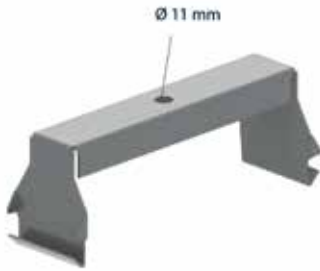

Standard finish	Pre-galvanised
Optional finish	Hot-dip galvanised
Optional finish PE	Coating

	Max. load (in daN)
OBG050	200
OBG075	200
OBG100	200
OBG150	200
OBG200	200
OBG250	150
OBG300	150
OBG400	90

HD	Reference	↑ mm	↔ mm	→ ← mm	↔ mm	kg/ piece	📦	Stock	Unit
HD	OBG050	64	55		-	0.100	12	X	piece
HD	OBG075	64	80		-	0.130	12	X	piece
HD	OBG100	64	105		-	0.140	12	X	piece
HD	OBG150	64	155		-	0.190	12	X	piece
HD	OBG200	64	205		-	0.220	12	X	piece
HD	OBG250	64	255		-	0.270	12	X	piece
HD	OBG300	64	305		-	0.310	6	X	piece
HD	OBG400	64	405		-	0.390	6	X	piece

To order per full packaging.

To be mounted with threaded rod TIM8 or TIM10.

OBGVF

Open C-suspension bracket for VFU(L)



Max. load	15 daN
Standard finish	Pre-galvanised

HD	Reference	↑ mm	↔ mm	→ ← mm	↔ mm	kg/ piece	📦	Stock	Unit
-	OBGVF050	135	55		-	0.175	12	X	piece
-	OBGVF100	135	102		-	0.245	12	X	piece

The technical information for this product can be found at the end of this chapter.

To order per full packaging.

To be mounted with threaded rod TIM6 or TIM8.

Max. load (in daN): uniformly distributed over complete width of cantilever brackets.

BGVF

External suspension bracket for VFU(L)

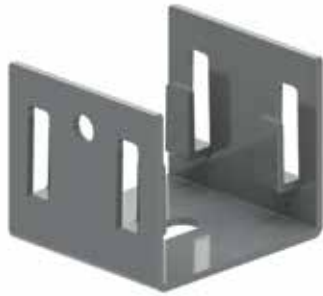

Max. load 70 daN

Standard finish Pre-galvanised

HD	Reference	↑ mm	↔ mm	→ ← mm	↔ mm	kg/ piece	📦	Stock	Unit
-	BGVF050	51	55		-	0.106	12	X	piece
-	BGVF100	51	102		-	0.154	24	X	piece

The technical information for this product can be found at the end of this chapter.

To order per full packaging.

To be mounted with threaded rod TIM6 or TIM8.

Max. load (in daN): uniformly distributed over complete width of cantilever brackets.

VFVLB

Floor bracket for VFU(L)



Standard finish

Stainless Steel

HD	Reference	↑ mm	↔ mm	→ ← mm	↔ mm	kg/ piece	📦	Stock	Unit
-	VFVLB	-			-	0.030	20	X	piece

To order per full packaging.

Up to width 250 mm, minimum 2 pieces per meter.

As from width 300 mm, minimum 4 pieces per meter.

ZCL

Z-support clippable



Standard finish

Pre-galvanised

Optional finish

Hot-dip galvanised

	Max. load (in daN)
ZCL100	150
ZCL150	150
ZCL200	120
ZCL300	105
ZCL400	90
ZCL500	80
ZCL600	65

HD	Reference	↑ mm	↔ mm	↔ mm	↔ mm	kg/ piece	📦	Stock	Unit
HD	ZCL100	14	60		180	0.135	12	X	piece
HD	ZCL150	14	60		230	0.165	12	X	piece
HD	ZCL200	14	60		280	0.210	12	X	piece
HD	ZCL300	14	60		380	0.265	12	X	piece
HD	ZCL400	14	60		480	0.315	12	X	piece
HD	ZCL500	14	60		580	0.365	12	X	piece
HD	ZCL600	14	60		680	0.415	12	X	piece

To order per full packaging.

MPVFCL

Profile for VFU(L)

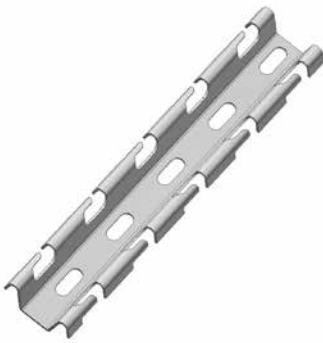

Standard finish

Pre-galvanised

Optional finish

Hot-dip galvanised

HD	Reference	↑ mm	↔ mm	↔ mm	↔ mm	kg/m	📦	Stock	Unit
HD	MPVFCL3000	27	55		3000	1.009	30		m

The technical information for this product can be found at the end of this chapter.

Do not use with: VFUL30.065, VFUL35.150, VFU35.150, VFUL 60.050

COMEGACLU170

Open suspension bracket universal



Useful for direct mounting to the ceiling or with threaded rod TIM8 or TIM10.

Standard finish	Pre-galvanised
Optional finish	Hot-dip galvanised
Optional finish PE	Coating

	Max. load (in daN)	A
COMEGACLU170.150	60	145
COMEGACLU170.200	60	145
COMEGACLU170.300	50	195
COMEGACLU170.400	40	245

HD	Reference	↑ mm	↔ mm	→ ← mm	↔ mm	kg/ piece	📦	Stock	Unit
HD	COMEGACLU170.150	175	194		-	0.460	12	X	piece
HD	COMEGACLU170.200	175	244		-	0.540	12	X	piece
HD	COMEGACLU170.300	175	344		-	0.700	6	X	piece
HD	COMEGACLU170.400	175	444		-	0.860	6	X	piece

To order per full packaging.

Fixing of the cable tray by VM6.20.

Use the VOMEGA to avoid compression of the profile.

Max. load (in daN): uniformly distributed over complete width of cantilever brackets.

Do not use with: VFUL30.065, VFUL35.150, VFU35.150, VFUL 60.050

COMEGACLU290

Open suspension bracket universal



Useful for direct mounting to the ceiling or with threaded rod TIM8 or TIM10.

Standard finish	Pre-galvanised
Optional finish	Hot-dip galvanised
Optional finish PE	Coating

	Max. load (in daN)	A
COMEGACLU290.100	70	145
COMEGACLU290.150	60	145
COMEGACLU290.200	60	145
COMEGACLU290.250	50	195
COMEGACLU290.300	50	195
COMEGACLU290.400	40	245

HD	Reference	↑ mm	↔ mm	↔ mm	↔ mm	kg/ piece	📦	Stock	Unit
HD	COMEGACLU290.100	290	145		-	0.520	12	X	piece
HD	COMEGACLU290.150	290	194		-	0.560	12	X	piece
HD	COMEGACLU290.200	290	244		-	0.620	12	X	piece
HD	COMEGACLU290.250	290	294		-	0.760	6	X	piece
HD	COMEGACLU290.300	290	344		-	0.820	6	X	piece
HD	COMEGACLU290.400	290	444		-	0.930	6	X	piece

To order per full packaging.

Fixing of the cable tray by VM6.20.

Use the VOMEGA to avoid compression of the profile.

Max. load (in daN): uniformly distributed over complete width of cantilever brackets.

Do not use with: VFUL30.065, VFUL35.150, VFU35.150, VFUL 60.050.

LOMEGACLU150

Wall bracket universal



Standard finish

Pre-galvanised

Optional finish

Hot-dip galvanised

Optional finish PE

Coating

	Max. load (in daN)
LOMEGACLU150.100	110
LOMEGACLU150.150	100
LOMEGACLU150.200	90
LOMEGACLU150.250	80
LOMEGACLU150.300	70
LOMEGACLU150.400	50
LOMEGACLU150.500	40
LOMEGACLU150.600	30

HD	Reference	↑ mm	↔ mm	↔ mm	↔ mm	kg/ piece	📦	Stock	Unit
HD	LOMEGACLU150.100	145	155		-	0.300	12	X	piece
HD	LOMEGACLU150.150	145	185		-	0.320	12	X	piece
HD	LOMEGACLU150.200	145	235		-	0.340	12	X	piece
HD	LOMEGACLU150.250	145	285		-	0.450	12	X	piece
HD	LOMEGACLU150.300	145	335		-	0.490	12	X	piece
HD	LOMEGACLU150.400	145	435		-	0.540	6	X	piece
HD	LOMEGACLU150.500	145	535		-	0.710	6	X	piece
HD	LOMEGACLU150.600	145	635		-	0.770	6	X	piece

To order per full packaging.

Fixing of the cable tray by VM6.20.

Use the VOMEGA to avoid compression of the profile.

Max. load (in daN): uniformly distributed over complete width of cantilever brackets.

Do not use with: VFUL30.065, VFUL35.150, VFU35.150, VFUL 60.050.

VMB

Floor and wall bracket

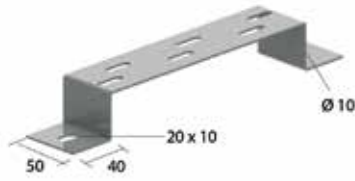

Suitable as floor-, wall-, and suspension bracket.

Max. load	200 daN
Standard finish	Pre-galvanised
Optional finish	Hot-dip galvanised
Optional finish PE	Coating

HD	Reference	↓ mm	↔ mm	→ ← mm	↔ mm	kg/ piece	📦	Stock	Unit
HD	VMB100	40	100		100	0.190	12	X	piece
HD	VMB150	40	150		150	0.220	12	X	piece
HD	VMB200	40	200		200	0.260	12	X	piece
HD	VMB300	40	300		300	0.330	12	X	piece
HD	VMB400	40	400		400	0.390	6	X	piece
HD	VMB500	40	500		500	0.460	6	X	piece
HD	VMB600	40	600		600	0.530	6	X	piece

The technical information for this product can be found at the end of this chapter.

To order per full packaging.

Floor bracket and suspension bracket: to mount with VFCL.

Wall bracket: to mount with VFK.

SLOS

Bolt-in partition



Standard finish	Pre-galvanised
Optional finish	zinc magnesium
Optional finish PE	Coating

HD	Reference	↓ mm	↔ mm	→ ← mm	↔ mm	kg/m	📦	Stock	Unit
-	SLOS35	28			3000	0.330	150	X	m
-	SLOS60	53			3000	0.511	120	X	m
-	SLOS85	78			3000	0.680	60	X	m
-	SLOS110	103			3000	0.820	30	X	m
-	ZMSLOS35	28			3000	0.257	150	X	m
-	ZMSLOS60	60			3000	0.397	120	X	m
-	ZMSLOS85	78			3000	0.529	60		m
-	ZMSLOS110	103			3000	0.638	30	X	m

Fix with:

-	VFSLOSCL	-	-	-	-	0.003	100	X	piece
HD	VFK	-	-	-	-	0.020	100	X	piece

The technical information for this product can be found at the end of this chapter.

Fixing set: 1 per meter.

VFSLOSCL

Clips for fixing SLOS to VFU(L)



Clips for fixing the division plate SLOS to VFU(L).

Standard finish

Spring steel

HD	Reference	↑ mm	↔ mm	→ ← mm	↔ mm	kg/ piece	📦	Stock	Unit
-	VFSLOSCL	-			-	0.003	100	X	piece

To order per full packaging.

VFK

Joining clamp

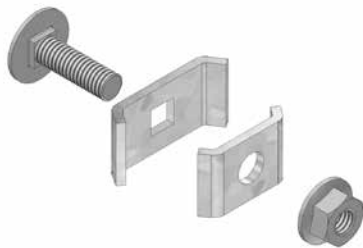

Standard finish

Pre-galvanised

Optional finish

Hot-dip galvanised

Optional finish PE

Coating

HD	Reference	↑ mm	↔ mm	→ ← mm	↔ mm	kg/ piece	📦	Stock	Unit
HD	VFK	-			-	0.020	100	X	piece

The technical information for this product can be found at the end of this chapter.

To order per full packaging.

Included: Bolt RBK6.20 and nut RM6.

VFKG30

Joining clamp for VFU(L)

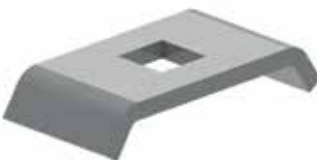

Standard finish

Pre-galvanised

Optional finish

Hot-dip galvanised

Optional finish PE

Coating

HD	Reference	↑ mm	↔ mm	→ ← mm	↔ mm	kg/ piece	📦	Stock	Unit
HD	VFKG30	-	30		-	0.020	100	X	piece

To order per full packaging.

VFKK25

Joining clamp for VFU(L)



Standard finish	Pre-galvanised
Optional finish	Hot-dip galvanised
Optional finish PE	Coating

HD	Reference	↓ mm	↔ mm	↔ mm	↔ mm	kg/ piece	📦	Stock	Unit
HD	VFKK25	-	25		-	0.020	100	X	piece

To order per full packaging.

VFKS

Support joiner for VFU(L)



For maximum stability and safety. Can only be used with VFU(L)60

Standard finish	Pre-galvanised
Optional finish	Hot-dip galvanised
Optional finish PE	Coating

HD	Reference	↓ mm	↔ mm	↔ mm	↔ mm	kg/ piece	📦	Stock	Unit
HD	VFKS	55	250		-	0.270	20	X	piece

To order per full packaging.

Included: 3x bolt RBK6.20, 3x nut RM6 and 3x VFKG30.

KPVF

Snap-on joiner for VFU(L)



For quick joining without bolts and nuts. Can only be used with VFU(L)60, VFU85, VFU110.

Standard finish	Pre-galvanised
Optional finish	zinc magnesium
Optional finish PE	Coating

HD	Reference	↑ mm	↔ mm	→ ← mm	↔ mm	kg/ piece	📦	Stock	Unit
-	KPVF	51	248		-	0.100	30	X	piece
-	ZMKPVF	51	248		-	0.100	30	X	piece

To order per full packaging.

KPVFL35

Snap quick-joiner for VFU(L)35



For quick joining of VFUL35 without bolts and nuts.

Standard finish	Pre-galvanised
Optional finish	zinc magnesium
Optional finish PE	Coating

HD	Reference	↑ mm	↔ mm	→ ← mm	↔ mm	kg/ piece	📦	Stock	Unit
-	KPVFL35	45	248		-	0.100	30	X	piece
-	ZMKPVFL35	45	248		-	0.100	30	X	piece

To order per full packaging.
Do not use with VFUL30.065.

V35.200

Joiner



Standard finish	Pre-galvanised
Optional finish	Hot-dip galvanised
Optional finish PE	Coating

HD	Reference	↑ mm	↔ mm	→ ← mm	↔ mm	kg/ piece	📦	Stock	Unit
HD	V35.200	25	200		-	0.040	10	X	piece

To order per full packaging.

RSM

Universal Roof Support



Construction foot for stable placement of light to medium weight cable support systems on roofs. Mechanical connections by means of 3x M6 screw holes in the top.
Filled with concrete.

HD	Reference	↑ mm	↔ mm	↔ mm	↔ mm	kg/ piece	📦	Stock	Unit
-	RSM	79	139		139	1,000	12	X	piece

The technical information for this product can be found at the end of this chapter.

To order per full packaging.

RSL

Universal Roof Support Large



Large base for placing heavier cable support systems on roofs.
Mechanical connection by means of Unistrut 41x41mm profiles.

HD	Reference	↑ mm	↔ mm	↔ mm	↔ mm	kg/ piece	📦	Stock	Unit
-	RSL	120	305		305	1,599	6	X	piece

The technical information for this product can be found at the end of this chapter.

To order per full packaging.

VFKNIP

Bolt cutter



Bolt cutter with offset cut

HD	Reference	↑ mm	↔ mm	↔ mm	↔ mm	kg/ piece	📦	Stock	Unit
-	VFKNIP	-			-	0.750	1	X	piece

GVFUL

Technical information

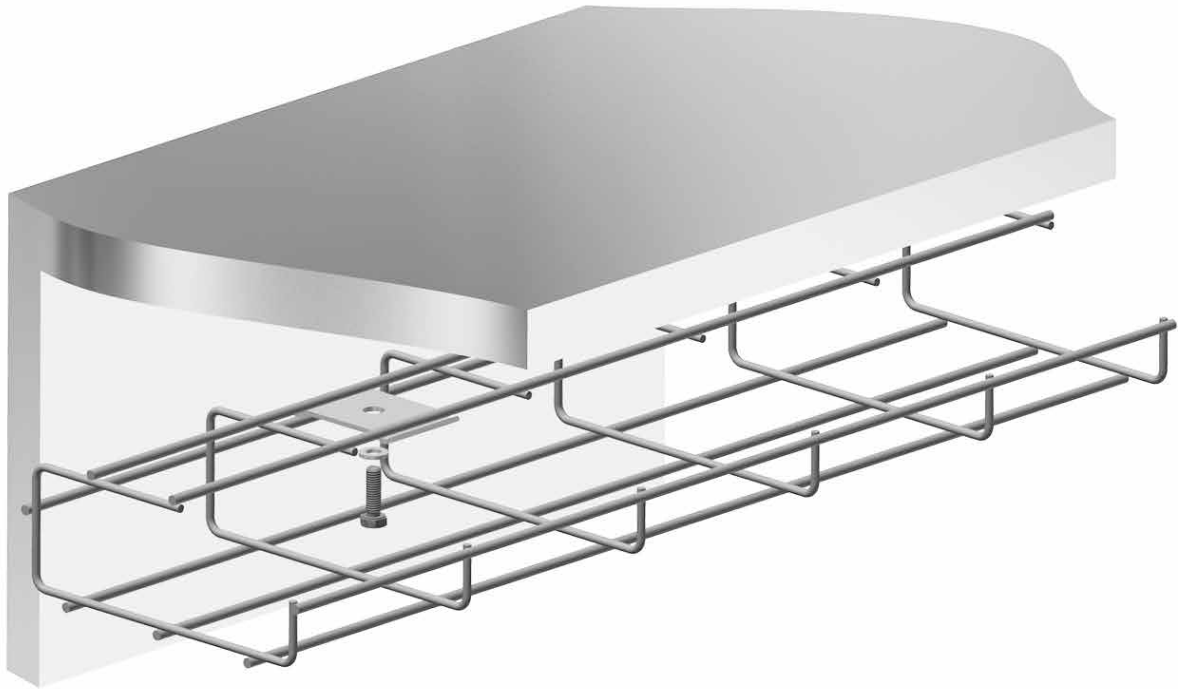

DCLVF

Technical information

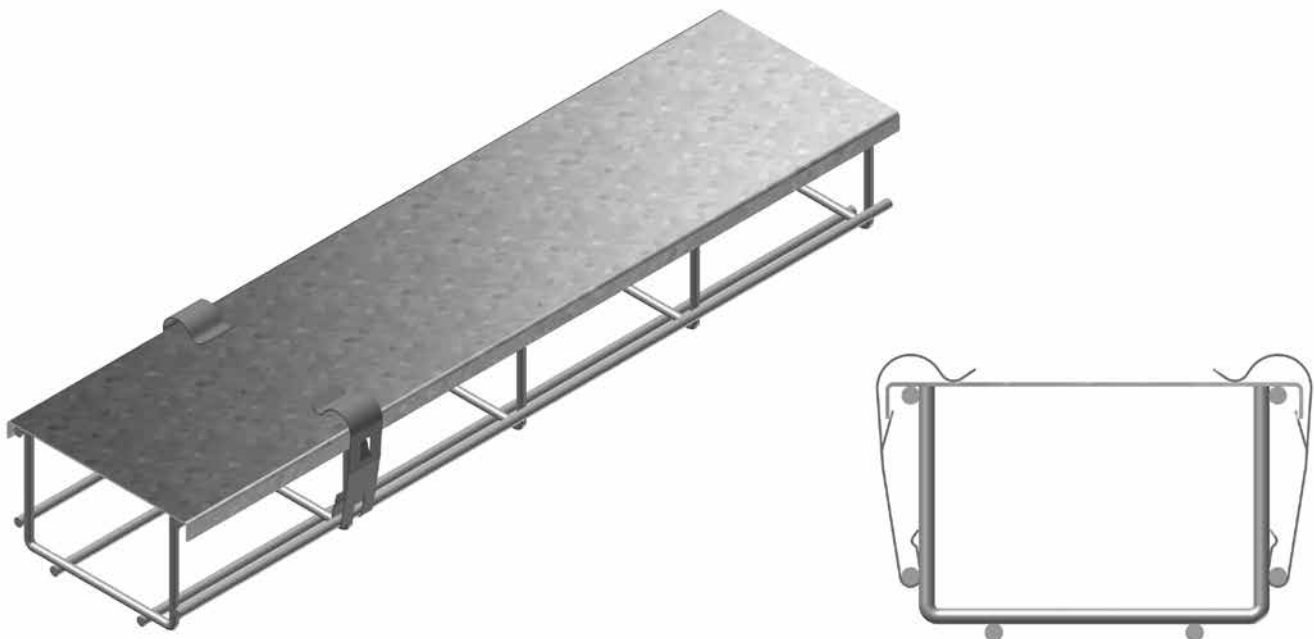

For VFU(L)60, VFU85 and VFU110.

DCLVF35

Technical information

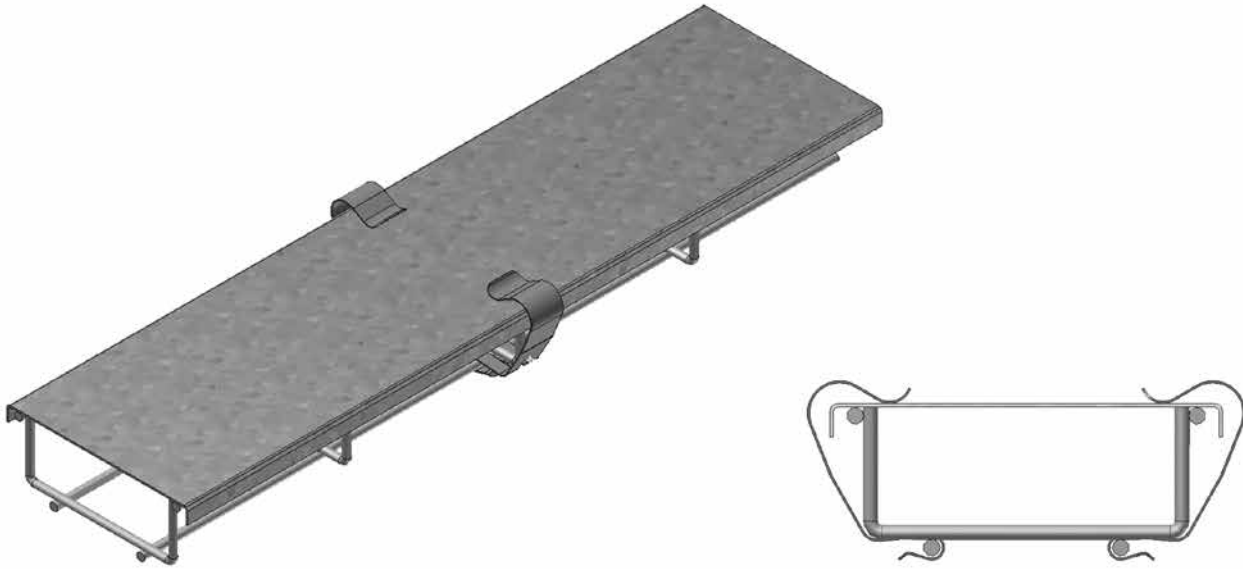

For VFU(L)35

VFMM

Technical information

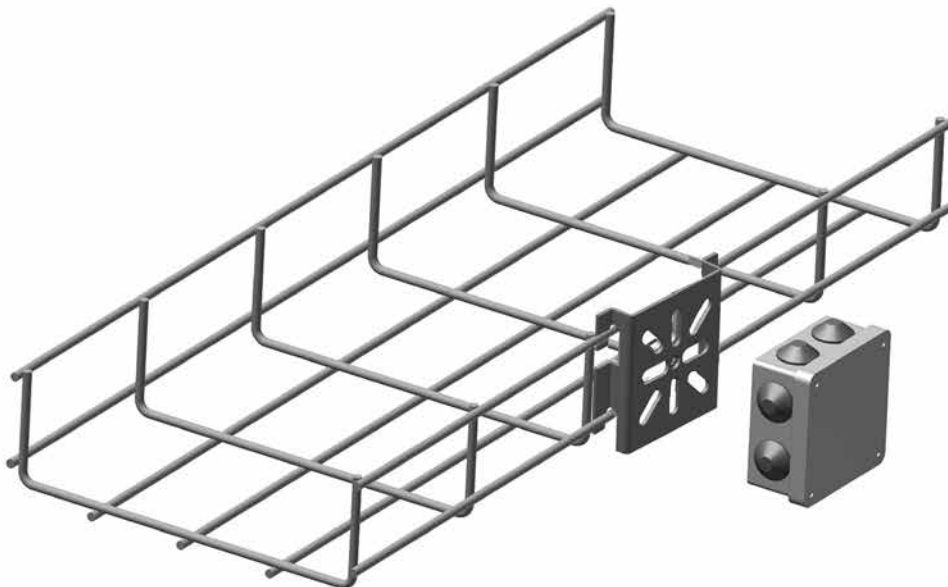

For fixing of contact boxes and wall fixing.

OBGVF

Technical information

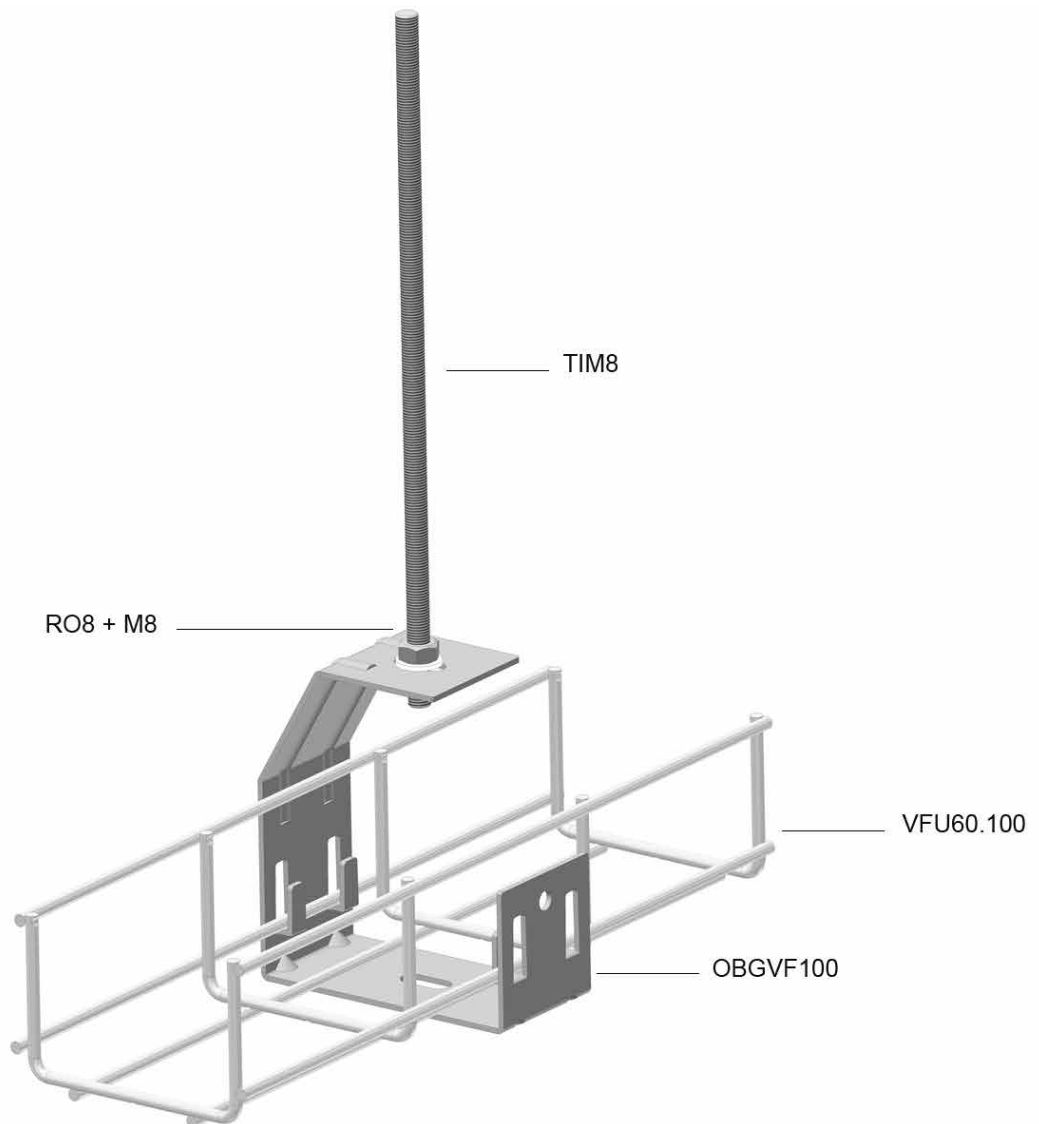

BGVF

Technical information

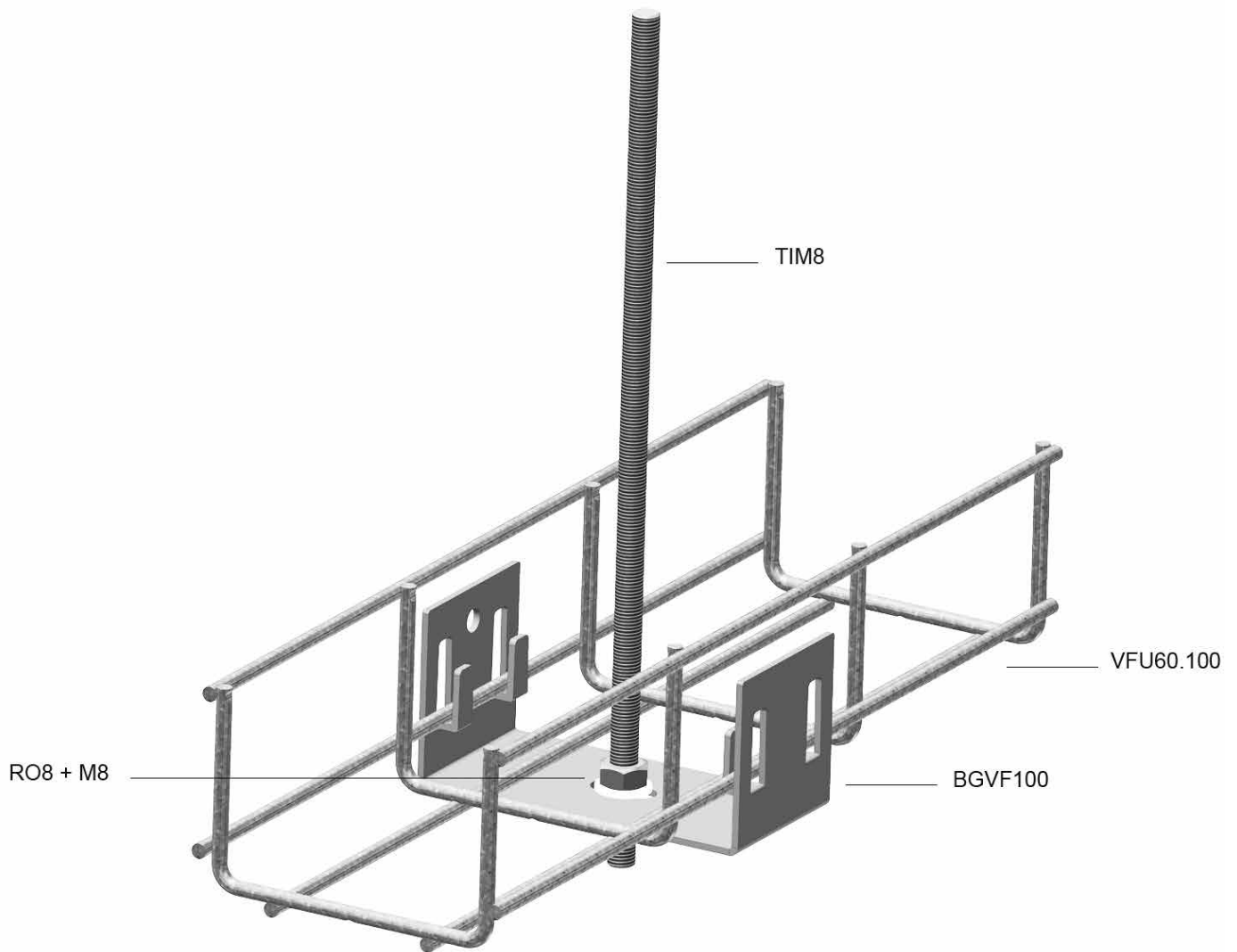

MPVFCL

Technical information

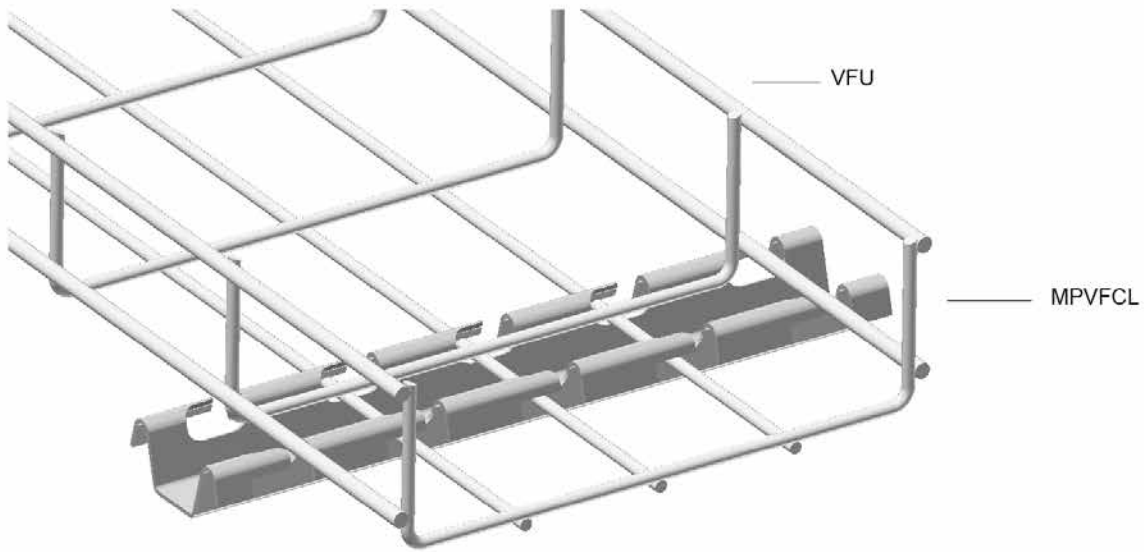

VMB

Technical information

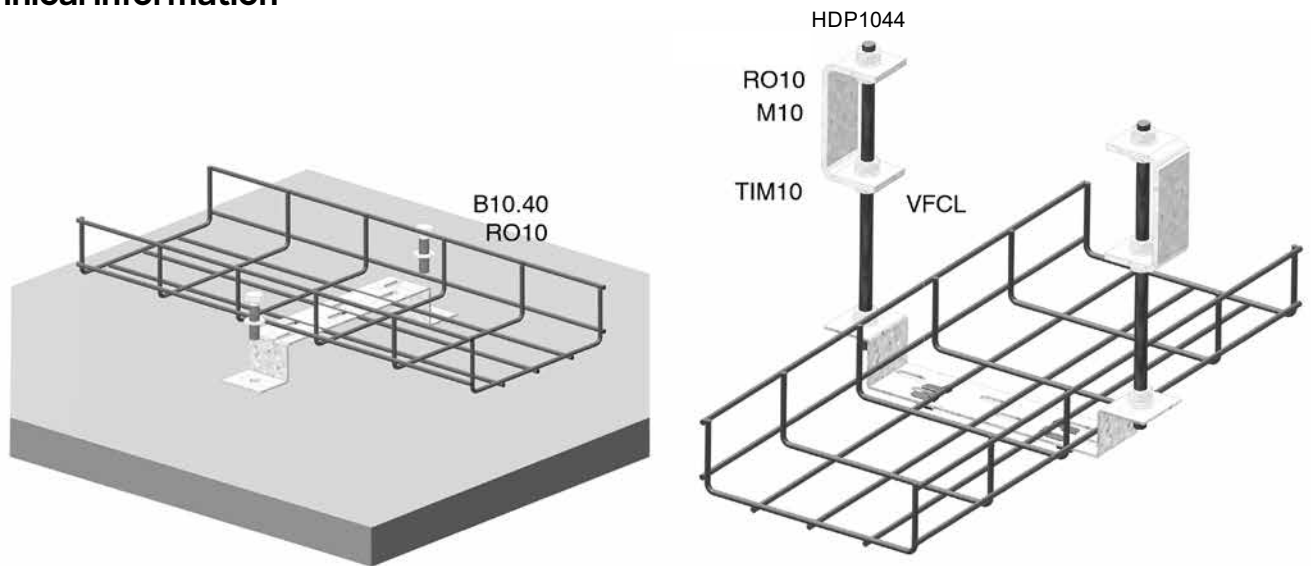

Suitable as floor-, wall-, and suspension bracket.
 Floor bracket and suspension bracket: to mount with VFCL.
 Wall bracket : to mount with VFK.

SLOS

Technical information

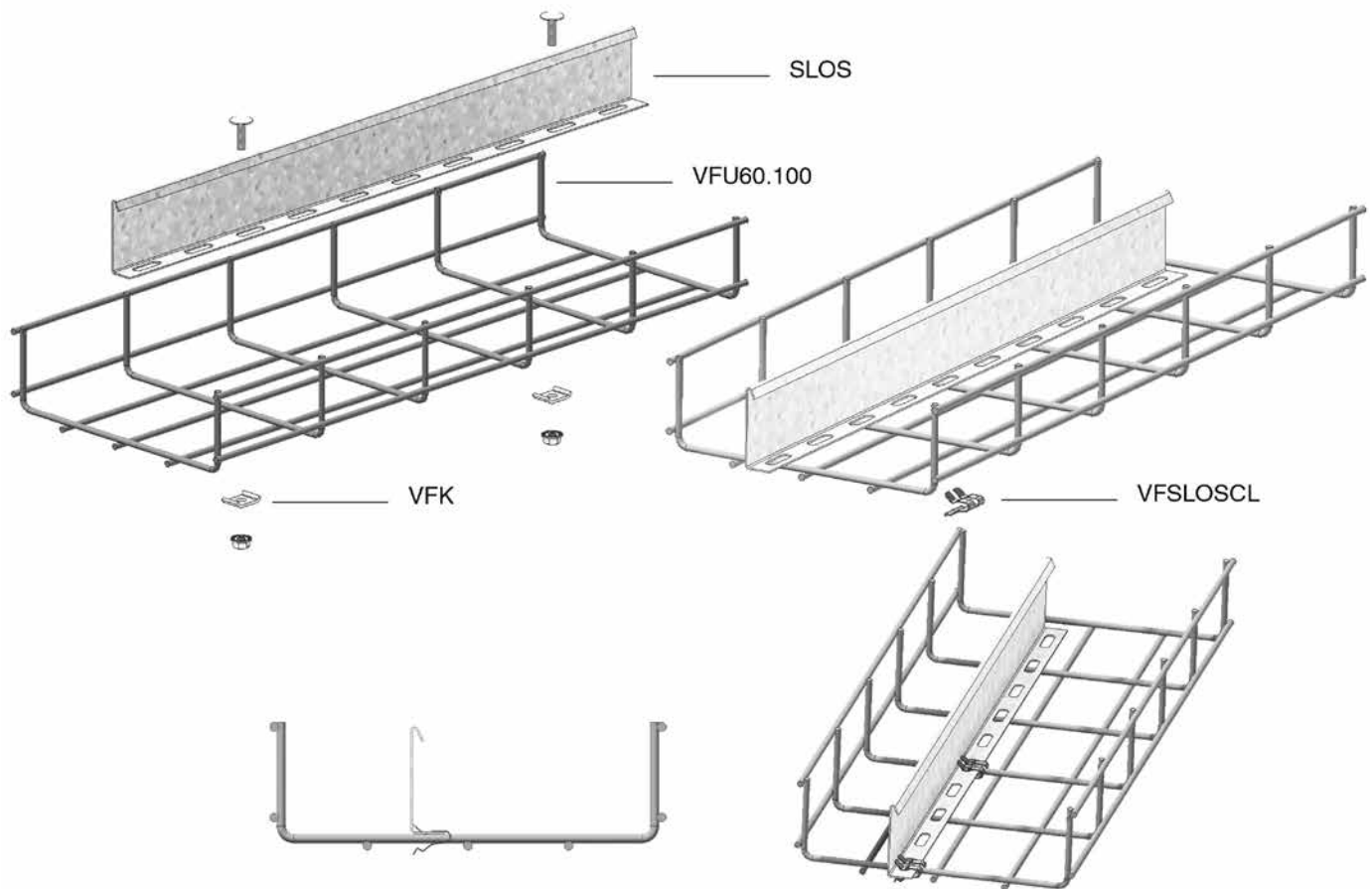

VFK

Technical information

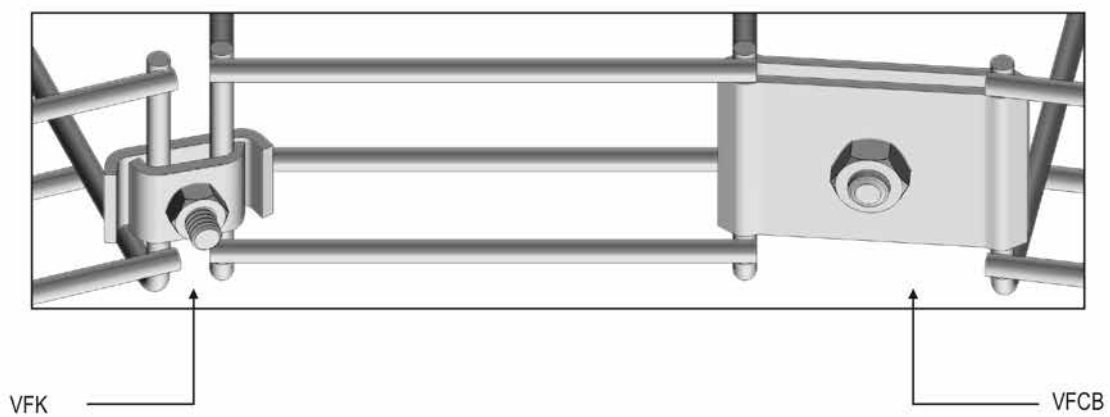

RSM

Technical information

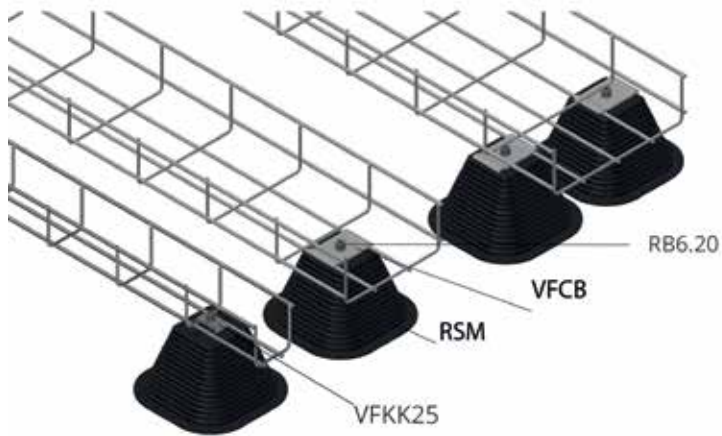

RSL

Technical information

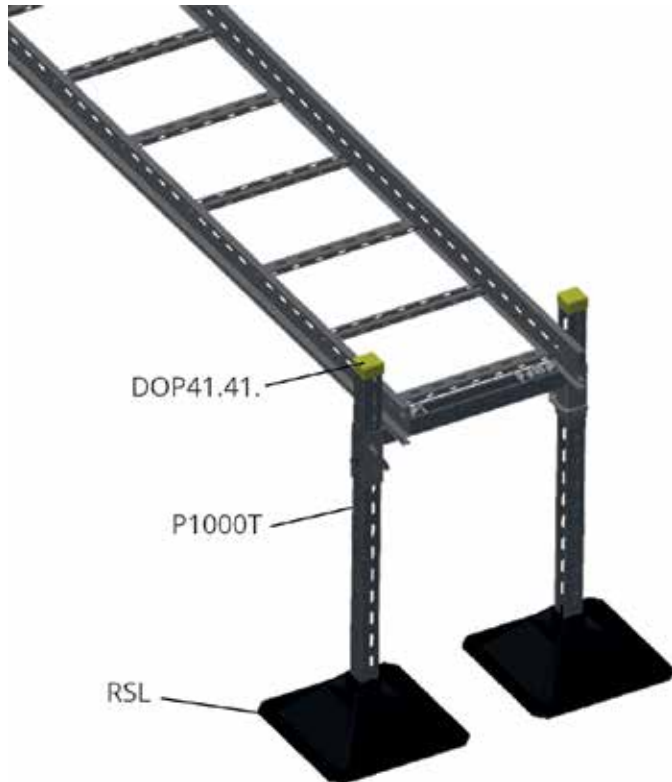

HOW TO CUT THE WIRE

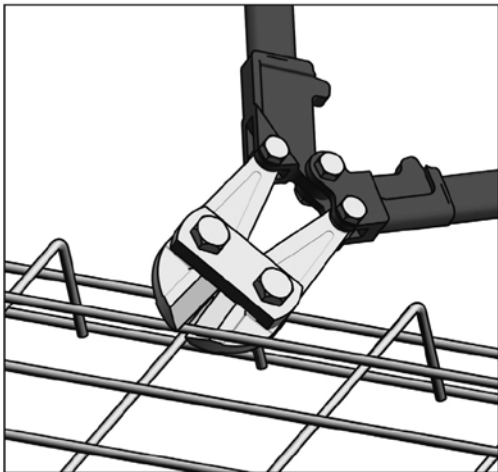

The shape of the cable basket can be changed to your requirements. For cutting of the wire mesh, we recommend the use of a professional set of cutting pliers with offset cut (drawing here below). The cutting of the wire is by preference being done as close as possible to the crossing of the wires, in order to prevent cable damage.

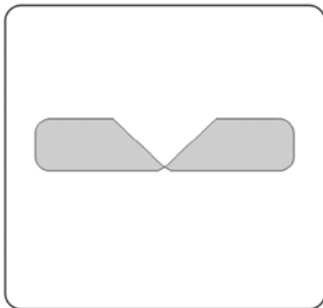

yes
Offset cut

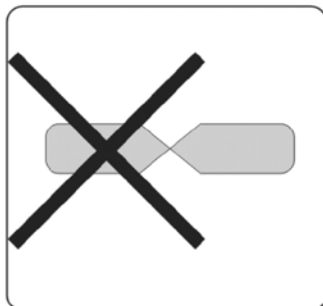

no
Central cut

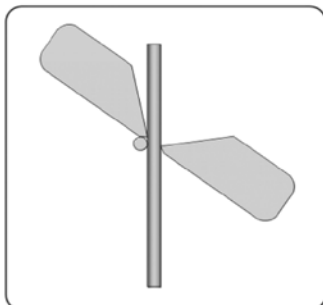

Placing of the clamping jaws

BEND WITH LARGE RADIUS

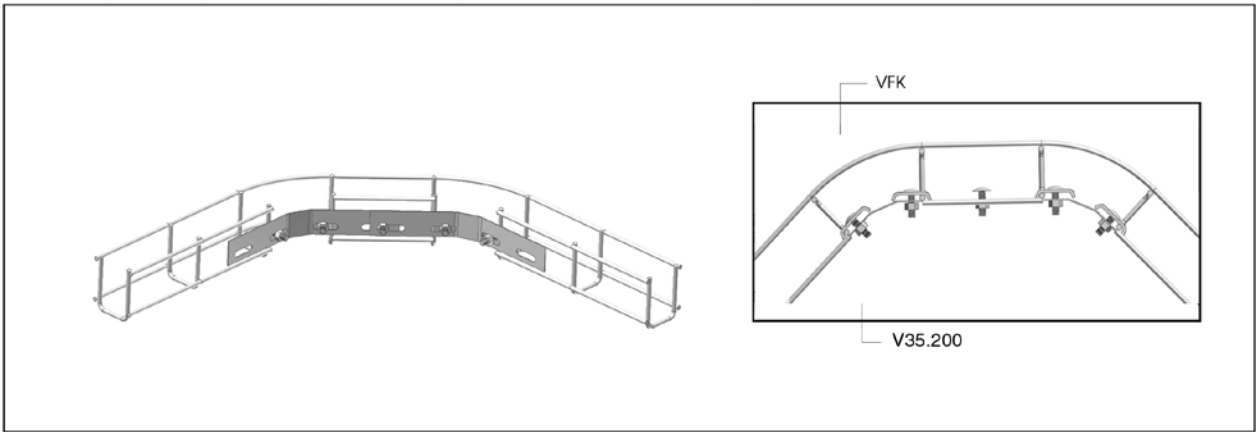

Widths 100 - 550 mm

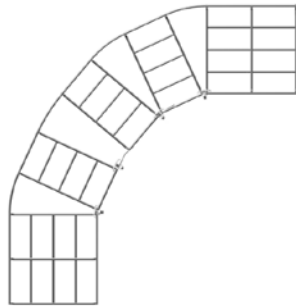
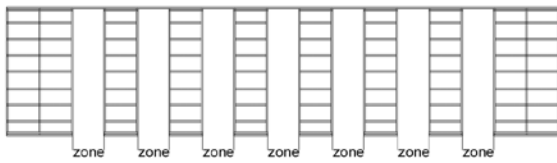
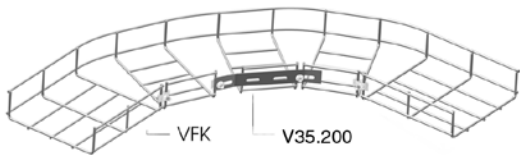

Width	Height	Zones	VFK	VFCB	V35.200
100	35/60	3	2	2	1
150	35/60	3	4	-	1
200	35/60	4	4	-	1
250	35	5	6	-	1
300	60	5	5	-	-
350	35	6	6	-	-
400	60	7	7	-	-
450	35	8	8	-	-
500	60	9	9	-	-
550	35	10	10	-	-

Fixation possibilities

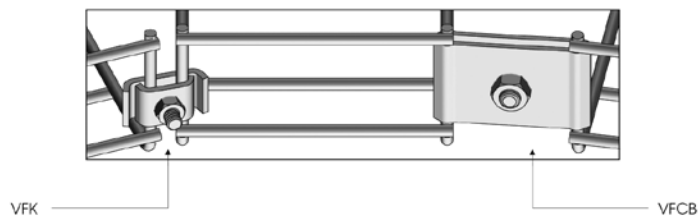

BEND WITH SMALL RADIUS

Method A

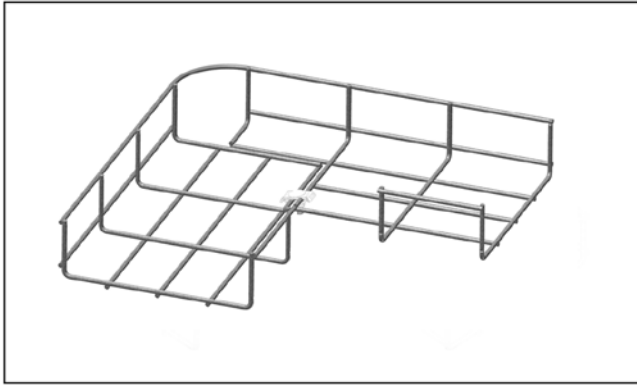

Method B

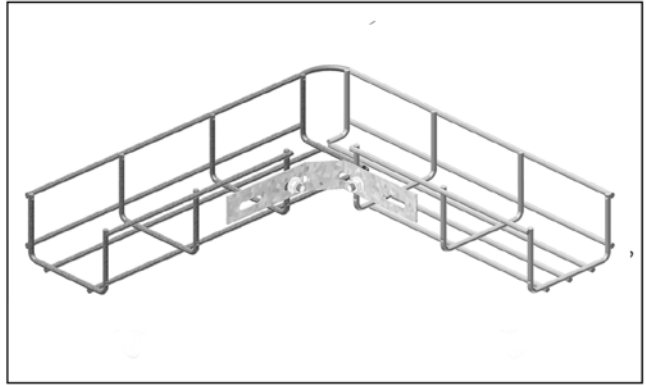

Width	Height	VFK	V35.200	Zones	Mounted	Method	Length
100	35/60	2	1			B	269,5
150	35	2	1			B	269,5
150	60	2	1			B	269,5
200	35	1	0			B	369,5
200	60	1	0			A	369,5
250	35	2	1			B	369,5
300	60	2	0			A	469,5
350	35	2	1			B	469,5
400	60	2	0			A	569,5
450	35	2	1			B	569,5
500	60	3	0			A	669,5
550	35	2	1			B	669,5
600	60	4	0			A	679,5

To make a small radius bend, one has to take a length of cable basket and cut away the necessary zones out of the bottom and the side. Then bend the cable basket to an angle of 90° and connect both ends by means of method A or B as mentioned in the table above. For the cable basket, width 50, only a large radius can be made.

T-PIECE

Type Wire cable tray

Reference	Number of zones to cut away
VFU(L)60.100	2
VFUL60.150	3
VFU85.100	2
VFU85.250	4
VFU85.350	5
VFU85.450	6

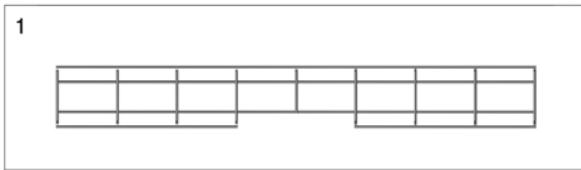

Equal for all widths

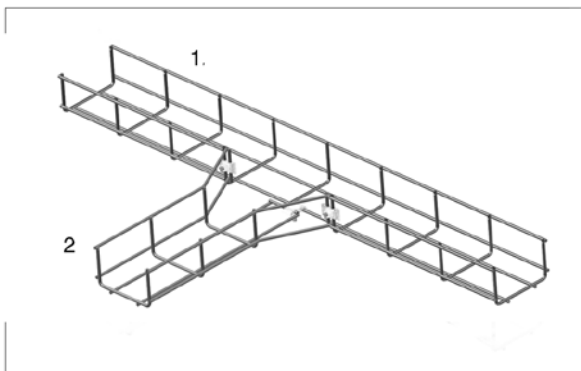
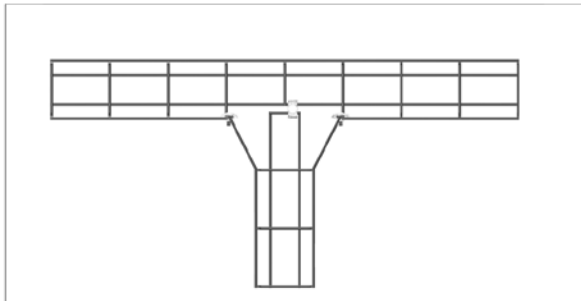
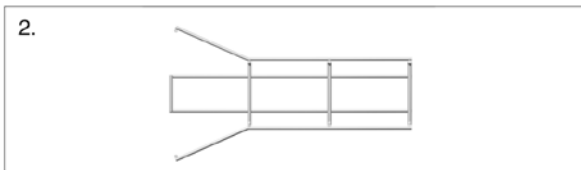

Type Wire cable tray

Reference	Number of zones to cut away
VFU(L)60.200	4
VFU(L)60.300	5
VFU60.400	6
VFU60.500	7
VFU60.600	8
VFU85.150	3
VFU110.200	4
VFU110.300	5
VFU110.400	6

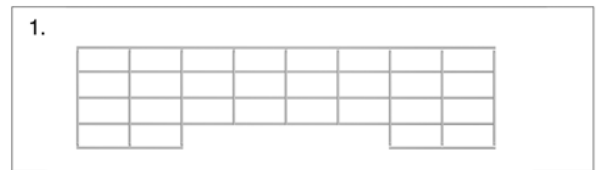

Equal for all widths

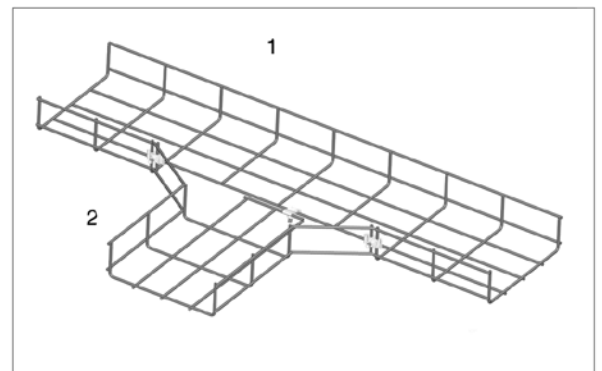
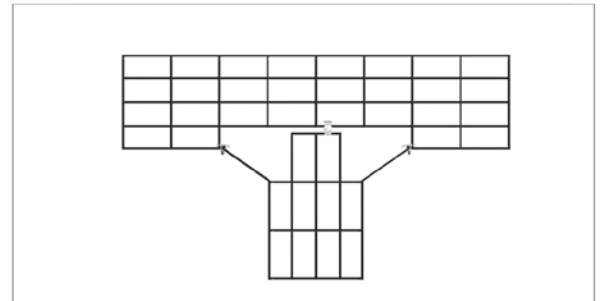
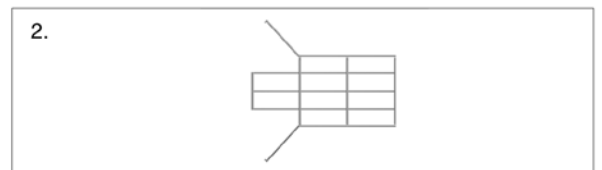

A T-piece is being made by cutting away the side of the basket tray (no 1), according to the data mentioned in the table above. Always the same zones will have to be cut away in basket tray (no 2). The remaining sides are being bend across each other. The basket trays are being coupled with VKF.

CROSS SECTION

Type Wire cable tray

Reference	Number of zones to cut away
VFU(L)60.100	2x 2
VFU(L)60.150	2x 3
VFU85.100	2x 2
VFU85.250	2x 4
VFU85.350	2x 5
VFU85.450	2x 6

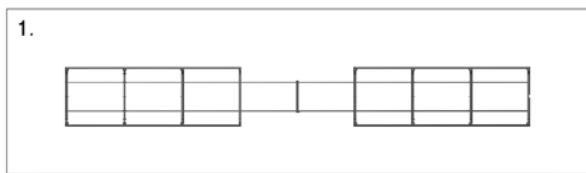

Equal for all widths

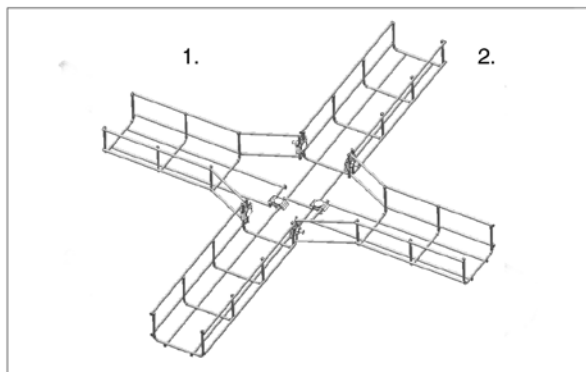
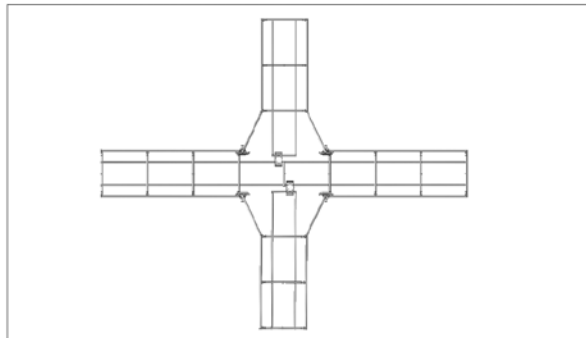
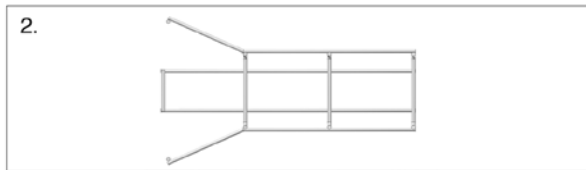

Type Wire cable tray

Reference	Number of zones to cut away
VFU(L)60.200	2x 4
VFU(L)60.300	2x 5
VFU60.400	2x 6
VFU60.500	2x 7
VFU60.600	2x 8
VFU85.150	2x 3
VFU110.200	2x 4
VFU110.300	2x 5
VFU110.400	2x 6

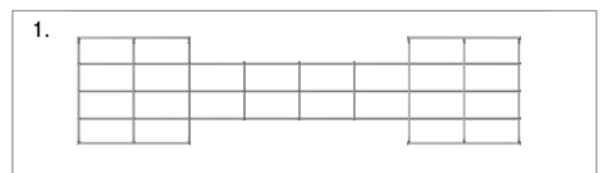

Equal for all widths

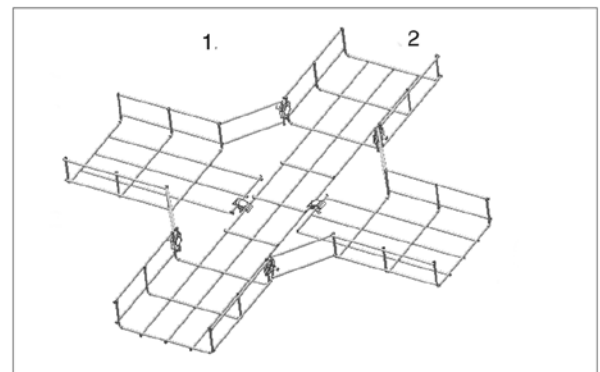
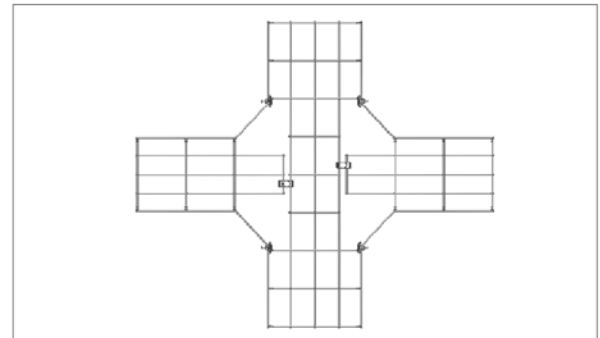
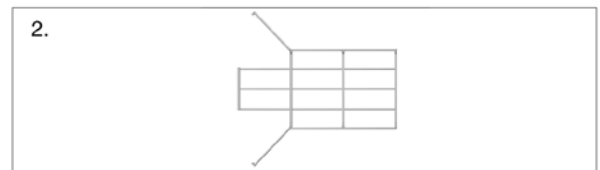

A cross-piece is being made by cutting away the side of the basket tray (no 1), according to the data mentioned in the table above. Always the same zones will have to be cut away in basket tray (no 2). The remaining sides are being bend across each other. The basket trays are being coupled with VFK.

LEVEL DIFFERENCES

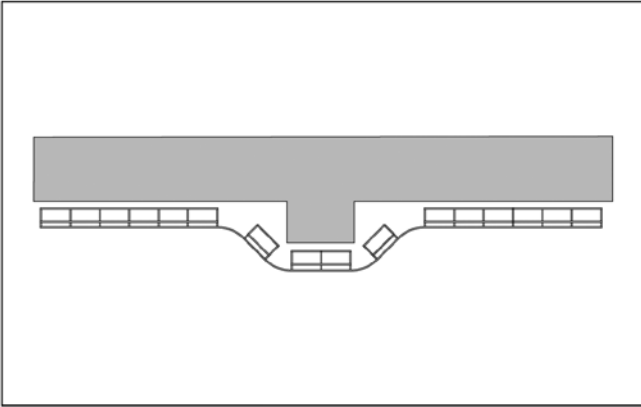

Any level difference can be obtained by cutting away the corresponding zone and bending the cable basket at that spot, until the required shape has been reached.
For extra reinforcement, the use of the connection plate V35.200 is being recommended.

Cutting and bending

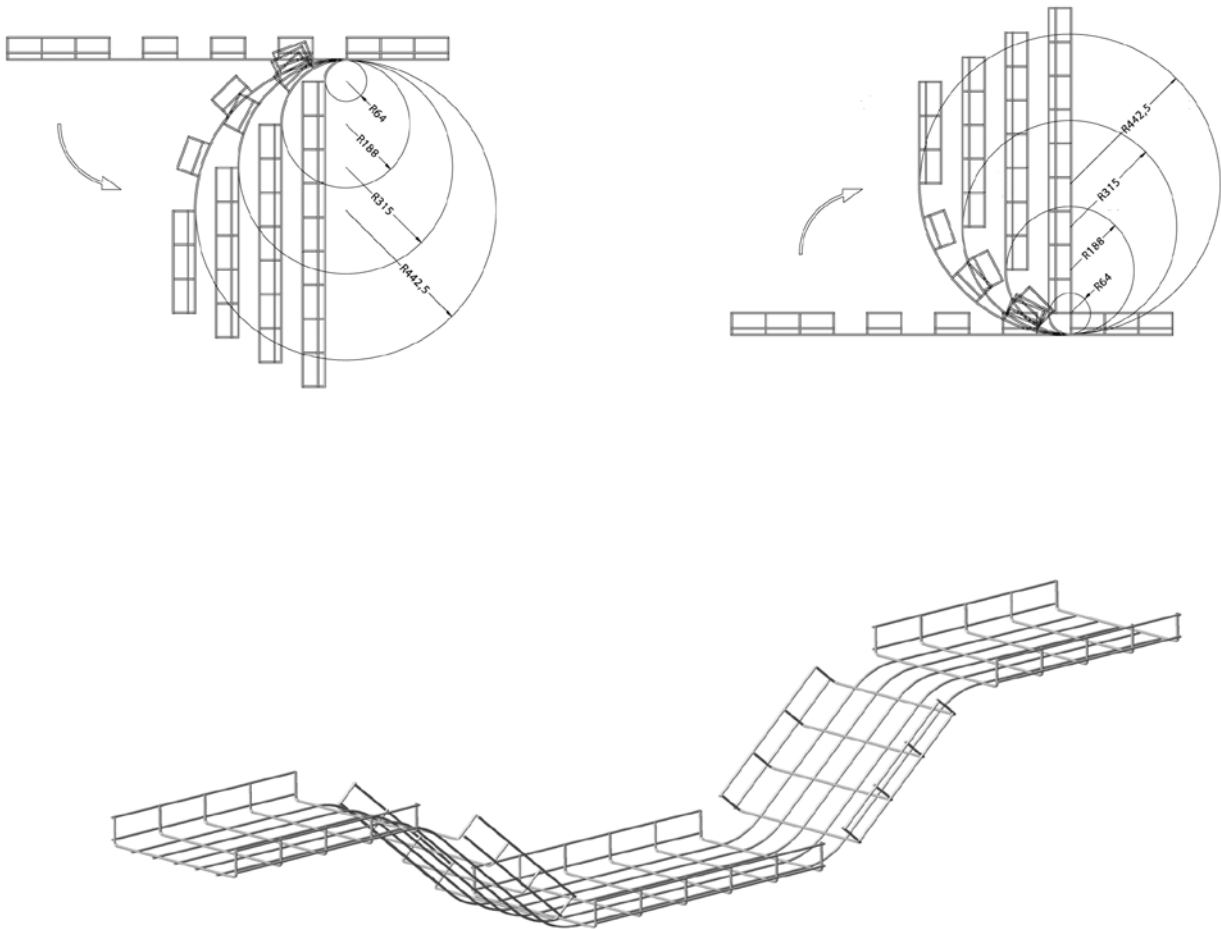

REDUCER

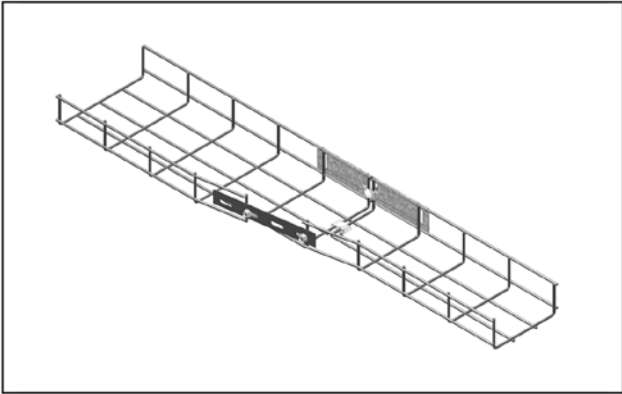

Cable basket can be reduced in order to connect them to a smaller section. All combinations are being based upon a few basic principles in order to obtain the required result.

1. Cut away the required zones from the bottom and the side.
2. Bend the side to the required width.
3. Connect the ends by means of KPVF, VFK and V35.200

Difference of 50mm

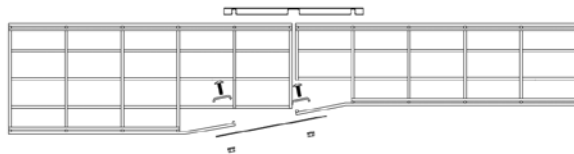
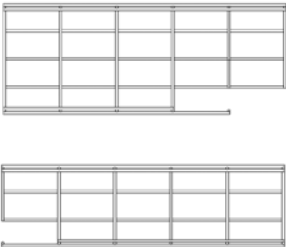

Difference of 100mm

